

WATER FOAM MONITOR

IFP-FIRESTORM

Description

The monitor Model - IFP FIRESTORM is durable manual controlled monitor for fixed installation. The monitor is generally used for protection of flammable liquid storage tanks, loading racks, dykes marine and many other Industrial applications.

The Monitor possess several design features that provides ease of operation, minimum maintenance and resistance to normally destructive environments. The monitor fitted with solid bore straight stream nozzle.

The monitor has welded carbon steel water way. All steel parts are hot dip galvanized and painted for excellent corrosion resistance. The vertical and horizontal rotation is through corrosion resistant bronze swiveling joint with double row of stainless steel ball bearing. Both vertical and horizontal movements are controlled with handle with twist lock.

The monitor has large flow capability and can be manually operated by a single fire fighter. The design ensures to prevent jet reaction forces from effecting the horizontal and the vertical position of the monitor. The monitor has the ability for 360 deg. continuous horizontal rotation and angle of elevation is adjustable with fix stop from +90 deg. above horizontal to -45 deg. below horizontal.

The water vane in discharge tube reduces the turbulence and friction loss, thus increasing the nozzle performance to achieve greater range. To ensure desired performance, the friction loss through monitor must be considered while selecting the nozzle and the flow through the monitor with reference to available base pressure at inlet of the monitor. For flow and jet reach data refer table.



Horizontal Straight Stream

Part Number	Monitor Size	Flow in lpm	Water Jet in metre	Horizontal Throw (Foam) in metres
401053	63	1750	53	45
401054	75	2580	60	50
401055	100	3500	64	55

Note:

Horizontal Straight Stream range is in still air with nozzle elevation at 30° to inlet flange at 1 to 1.5 meters above ground level and at 7 kg./ Sq.cm. nozzle pressure.



Approval

BIS marked as per IS:8442

Materials of Construction

Parameters	Material
Model	IFP FIRESTORM 1750 (WFM) IFP FIRESTORM 2580 (WFM) IFP FIRESTORM 3500 (WFM)
Base Flange	Mild Steel, IS 2062/Stainless Steel
Drain Valve	Stainless Steel/ Copper Alloy
Swivel Joint	Gun Metal LTB-2, IS:318
Lock Nut	Brass IS:291
Handle	Mild Steel IS : 1732
Water Barrel	Mild Steel IS:11428
Nozzle	Aluminum Alloy

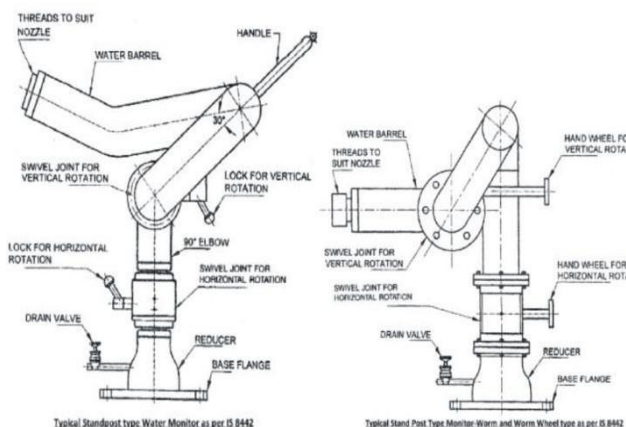

Technical Data (±5%)

Model	IFP FIRESTORM 1750 (WFM)	IFP FIRESTORM 2580 (WFM)	IFP FIRESTORM 3500 (WFM)
Part Number	401053	401054	401055
Maximum rated	12 bar (175 psi)	12 bar (175 psi)	12 bar (175 psi)
Nominal waterway	63 mm	75 mm	100 mm
Size	63 mm	75 mm	100 mm
Flow at 7 kg / cm² pressure	1750 lpm	2580 lpm	3500 lpm
Factory Hydrostatic Test Pressure	25 kg / cm ²	25 kg / cm ²	25 kg / cm ²
Inlet flange size	80 NB/100 NB	100 NB	100 NB/150 NB
Nozzle	Straight stream nozzle/ Jet-Spray nozzle	Straight stream nozzle	Straight stream nozzle
Colour	Fire Red Shade 536 of IS 5 : 1961 painted from outside	Fire Red Shade 536 of IS 5 : 1961 painted from outside	Fire Red Shade 536 of IS 5 : 1961 painted from outside
Horizontal rotation	360 Deg. continuous	360 Deg. continuous	360 Deg. continuous
Approval	BIS marked	BIS marked	BIS marked

Ordering Information

Part Number	Model
401053	IFP FIRESTORM 1750 (WFM)
401054	IFP FIRESTORM 2580 (WFM)
401055	IFP FIRESTORM 3500 (WFM)

Contacts in Emergency : +919903914042

Integrated Fire Protection Pvt. Ltd.

Corporate Office:

Siddha – Esplanade, Room 1105

6 Jawaharlal Nehru Road, Kolkata – 700013, India

Phone : +91 33 24541061, 24755634 | Fax : +91 33 2476 1107 | E-mail : info@integratedfire.net | Web : www.integratedfire.net

Registered Office:

60A, Pandit M M Malabya Sarani

Chakraberia Rd (N), Kolkata - 700 020 INDIA